

# TECHNICAL SPECIFICATIONS

## SERIES 1 – ESTIMATED

Following ongoing validation of the Series 1 Martin Jetpack design, adjustments have been made to certain of the original proposed capabilities. It should be noted that these technical specifications are based on current engineering estimates. Actual technical specifications will be confirmed on completion of the Prototype 14, which forms the basis of the Series 1 aircraft, build and subsequent live testing.

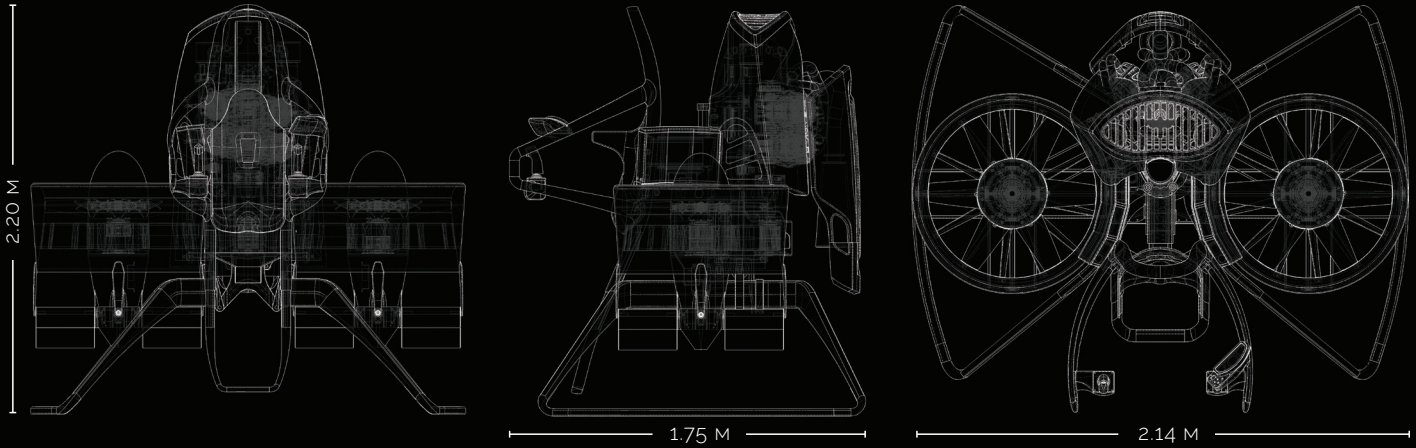

## General Characteristics

<b>TYPE</b>	Experimental Airworthiness Certificate
<b>OPTIONALLY PILOTED</b>	Single pilot or payload
<b>AIRCRAFT EMPTY WEIGHT</b>	+/- 230kg
<b>PAYLOAD AT FULL FUEL (PILOT + EQUIP)</b>	100kg
<b>ENGINE</b>	200hp. 30-hour time between overhaul.
<b>FUEL CAPACITY</b>	40 litres

## Composite Airframe Specifications

<b>DUCTS</b>	Carbon fibre, aramid fibre, honeycomb core, epoxy resin
<b>FANS</b>	Epoxy prepreg carbon fibre, aramid fibre, foam core
<b>MAIN BEAM</b>	High modulus carbon fibre, foam core
<b>SPINE</b>	Epoxy prepreg carbon fibre
<b>FUEL TANK</b>	Carbon fibre, Kevlar, fuel resistant epoxy resin
<b>UNDERCARRIAGE</b>	Carbon fibre, epoxy resin, aluminium alloy
<b>ENGINE HEADS</b>	Carbon fibre, high temp flame resistant vinylester resin
<b>AIRBOXES</b>	Carbon fibre, epoxy resin

## Performance

<b>RANGE</b>	15km – 20km
<b>ENDURANCE (FLIGHT TIME)</b>	28 minutes
<b>AIRSPEED</b>	40km/h
<b>CEILING</b>	2,500 ft AMSL (payload 100kg)

## Other Specifications

<b>FUEL AND OIL</b>	Runs on automotive gasoline
<b>STARTING</b>	Excludes on board starting function
<b>COMPUTER AIDED STABILITY</b>	"Fly by wire", no-pilot-control-input produces a zero air-speed hover
<b>BALLISTIC PARACHUTE</b>	Ultra low level opening Ballistic chute integrated into the FCS and EMS
<b>PILOT PROTECTION</b>	Protective pilot module and structural protection